

LOC	DIST	REVISIONS			
P	LTR	DESCRIPTION	DATE	DWN	APVD
G		EBD0-0129-03	06-06-03	SS	JA
H		EBD0-0028-05	20-01-05	AM	FWK
J		EBD0-0217-05	10-05-05	AM	FWK

SPECIFICATION DATA

Subminiature Range		
Amp Rating	5	
Insulation Resistance	Min. 100M ohm (at 500V DC)	
Contact Resistance	Max 50M ohm (by voltage drop, 1A 6V-8V DC)	
Dielectric Strength	Between terminals	1000Vrms for 1 min
	Between terminals & other exposed metal parts	1500Vrms for 1 min
	Between terminals and earth	1500Vrms for 1 min
Temperature rise	30°C Max	
Terminal Strength	6kg pulling and push torque shall be applied for 1min	
Allowable Operating Speed	0.1 to 1,000 mm/sec	
Shock resistance (without lever)	Min 30G (O.F.100g, 150g)	Contact opening max 1msec
	Min 15G (O.F.50g)	
Vibration resistance (without lever)	9G, 10 to 55 Hz at double amplitude of 1.5mm (contact opening, max 1msec)	
Electrical Life	5 x 10 power of 4 at 20cpm	
Mechanical Life	5 x 10 power of 4 at 60cpm	
Mechanical repeatability	300 cpm	
Safety Approval	UL / CSA	
Ambient temperature	-25°C to +85°C	

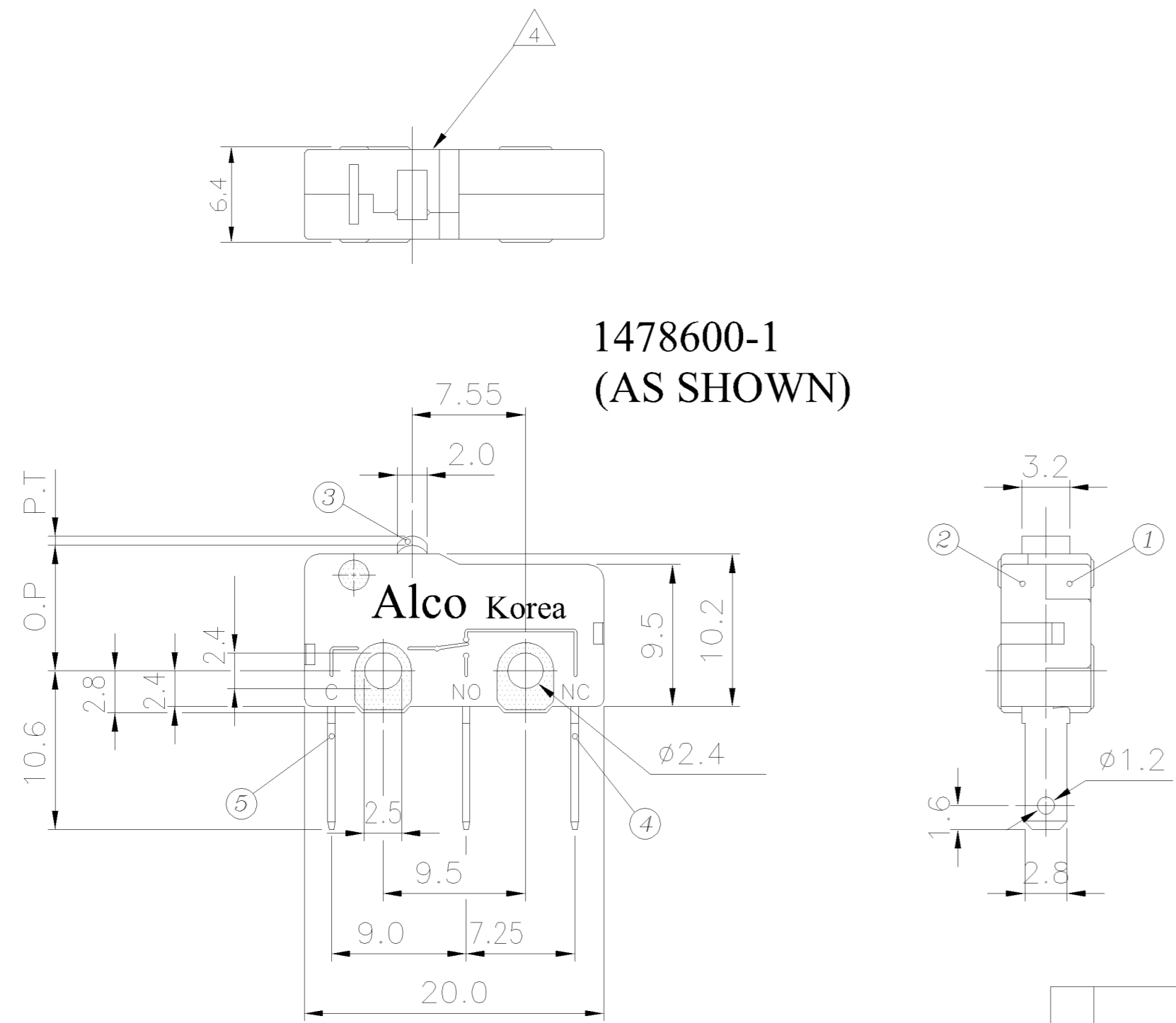

1478600-1
(AS SHOWN)

NO	DRAWING NO	△	CHARACTERISTICS					
			Operating Force	Releasing Force	Pre Travel	Operating Position	Over Travel	Movement Differential
1	1478600-1	—	Max 150 g	Min 20 g	Max 0.6 m/m	8.4 ±0.4 m/m	Min 0.3 m/m	Max 0.2 m/m
2	1478600-2	△	55 g	3.5 g	3.1 m/m	8.8 ±0.8 m/m	0.7 m/m	0.8 m/m
3	1478600-3	△	45 g	3.0 g	3.6 m/m	8.8 ±1.2 m/m	0.9 m/m	1.0 m/m
4	1478600-4	△	60 g	4.0 g	2.7 m/m	14.5 ±0.8 m/m	0.7 m/m	0.8 m/m
5	1478600-5	△	40 g	3.0 g	3.6 m/m	11.6 ±0.8 m/m	0.8 m/m	0.6 m/m

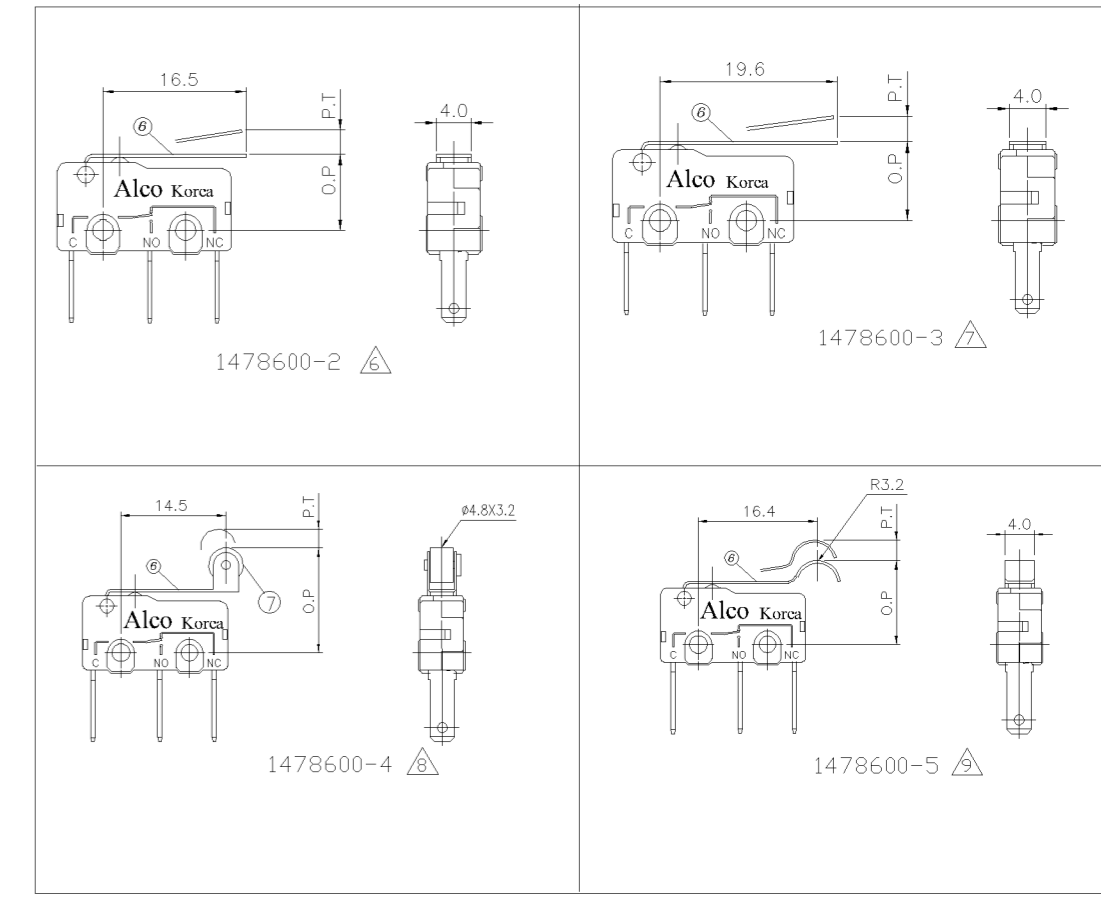

NOTES:

- FOR TECHNICAL DATA REFER TO YOUR LOCAL TYCO ELECTRONICS SALES OFFICE.
- ALL DIMENSIONS ARE NOMINAL. FOR REFERENCE ONLY UNLESS OTHERWISE STATED.
- ALL DIMENSIONS ARE COMMON TO THE MAIN BODY. VARIATIONS ARE IN THE OPERATING LEVERS.
- TYCO PART NUMBER AND LOT No. INKJET MARKED IN THIS AREA.
- GENERAL INFO.

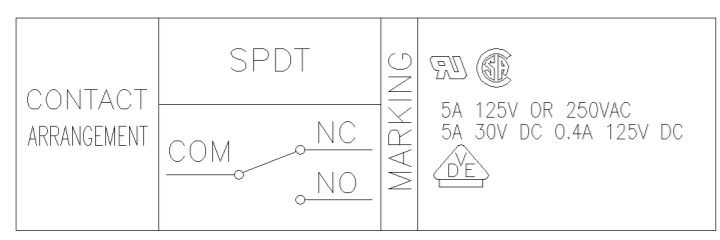

7	ROLLER	1
6	LEVER	1
5	COMMON TERMINAL	1
4	TERMINAL	2
3	BUTTON	1
2	COVER	1
1	BOX	1
NO	PART NAME	Q'TY

6 FOR PACKAGING INFORMATION SEE SPEC. 107-115

SP5-DT-CSMA	△	1478600-5	Microswitch, Simu Lever	Grey	1000	CARTON
SP5-DT-CNRD	△	1478600-4	Microswitch, Norm Roller	Grey	800	CARTON
SP5-DT-CLLB	△	1478600-3	Microswitch, Long Lever	Grey	1000	CARTON
SP5-DT-CNLC	△	1478600-2	Microswitch, Norm Lever	Grey	1000	CARTON
SP5-DT-COLE		1478600-1	Microswitch, Pin Plunger	Grey	1000	CARTON
TYCO SALES PART No.		TYCO PART NO.	DESCRIPTION	Colour	QTY	PACK DESC

THIS DRAWING IS A CONTROLLED DOCUMENT.

DIMENSIONS: MM	TOLERANCES UNLESS OTHERWISE SPECIFIED:	DWN P.Bates 14JAN2003	tyco Electronics Tyco Electronics Corporation Stanmore, Middlesex, HA7 4RS
0 PLC ± -	1 PLC ± 0.4	CHK C.Kaminski 18-10-01	
2 PLC ± 0.4	3 PLC ± -	APVD C.Kaminski 18-10-01	NAME
4 PLC ± -	ANGLES ± -	PRODUCT SPEC	MICRO SWITCH 5A
MATERIAL	FINISH	APPLICATION SPEC	4mm TAB
		WEIGHT	150g RANGE
		CUSTOMER DRAWING	SIZE A2 CAGE CODE 00779 DRAWING NO. C=1478600 RESTRICTED TO
		SCALE 1:1	SHEET 1 OF 2 REV J

THIS DRAWING IS UNPUBLISHED. RELEASED FOR PUBLICATION 18.12.00, 18.12.00
 © COPYRIGHT 2001 BY TYCO ELECTRONICS CORPORATION. ALL RIGHTS RESERVED.

LOC	DIST	REVISIONS					
		P	LTR	DESCRIPTION	DATE	DWN	APVD
E	B		G	EBD0-0129-03	06-06-03	SS	JA
			H	EBD0-0028-05	20-01-05	AM	FWK
			J	EBD0-0217-05	10-05-05	AM	FWK

MAJOR COMPONENT & MATERIAL LIST

NO	PART NAME	MATERIAL	Q'ty	UL FRAME	FINISH (COLOR)
1	CASE	1)P.B.T RESIN	1	94 V-0	
2	COVER	2)P.B.T RESIN 3)PA 66	1		
3	MOVABLE CONTACTOR	Beryllium Copper Sheet (t=0.10 or 0.12)	1		w/,w/o Silver plating
4	BUTTON	PHENOLIC RESIN	1	1)94 HB 2)94 V0	
5	COMMON TERMINAL	Brass Sheet (t=0.5)	1		SILVER PLATING
6	TERMINAL(NC)	Brass Sheet (t=0.5)	1		
7	TERMINAL(NO)	Brass Sheet (t=0.5)	1		
8	Movable Contact	Ag alloy (AgCu, AgCdO)	1		
9	Fixed Contact	Ag alloy (AgCu, AgCdO)	2		SILVER PLATING
10	LEVER	Stainless Steel Sheet (t=0.3)	(1)		

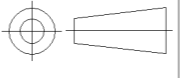
THIS DRAWING IS A CONTROLLED DOCUMENT.		DWN S.Shackson 06JUN2003	 Tyco Electronics Corporation Stanmore, Middlesex, HA7 4RS	
DIMENSIONS: MM		CHK F.Wheeler-King 06JUN2003		
TOLERANCES UNLESS OTHERWISE SPECIFIED:		APVD F.Wheeler-King 06JUN2003	NAME MICRO SWITCH 5A 4mm TAB 150g RANGE	
		PRODUCT SPEC -	SIZE A2	
MATERIAL		APPLICATION SPEC -	CAGE CODE 00779	DRAWING NO C=1478600
FINISH		WEIGHT -	RESTRICTED TO -	
		CUSTOMER DRAWING	SCALE 1:1	SHEET 2 OF 2
			REV J	